

VACUUM TRASH COMPACTOR

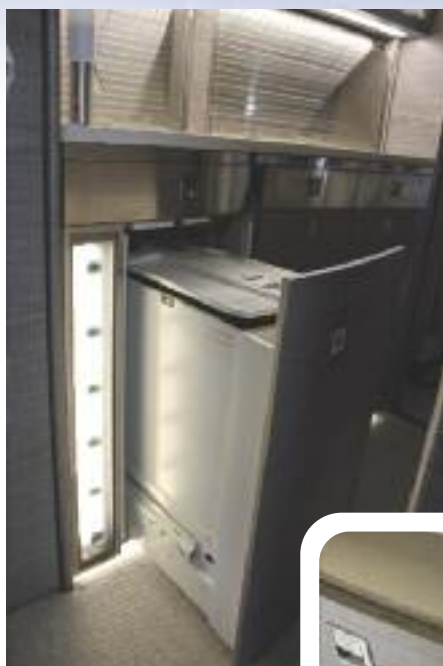

**FLYING ON 7X
CERTIFIED 8X**



VACUUM TRASH COMPACTOR CORPORATE

- Light weight : 20 kg
- Qualified for VIP waste
- Tailor-made solution
- Innovation

TEST PERFORMED ON A 45L COMPACTION BAG



Bag full at 90 %

Cardboards x 10, Aluminium food containers 10 x 1L,
 Cans x 25, Water bottles 6 x 1,5L, Plastic glasses x 40,
 Plastics trays x 10, Silicone gloves x 5 pairs,
 Paper towels x 30, Toothbrushes x 10,
 Handkerchiefs x 30, Milk cardboard 1,
 Fruits and vegetables : 1 melon, ½ Water Melon,
 4 tomatoes, 1 salad, 1 mozzarella...

TECHNICAL INFORMATION

CHARACTERISTICS

The following table presents key characteristics of the Airline/VIP solutions corporate Vacuum Trash Compactor.

Characteristics	Corporate
Dimensions HxDxW	633 x 535 x 266
Capacity	
Plastic glasses	105
Plastic bottles 50 cl	40
Aluminium cans	35
Plastic bottles 1L	4
Juice cardboards	7
Miniatures	5
Electrical interface	28 VDC
Consumption	< 200 W
Compaction bag	46 L
Weight	20 kg

The product can be customized to a dedicated galley integration.

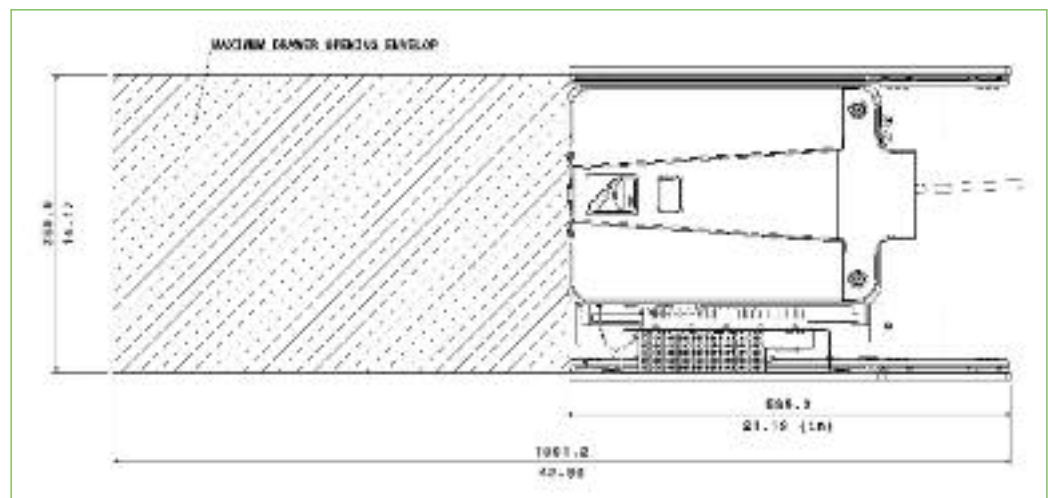
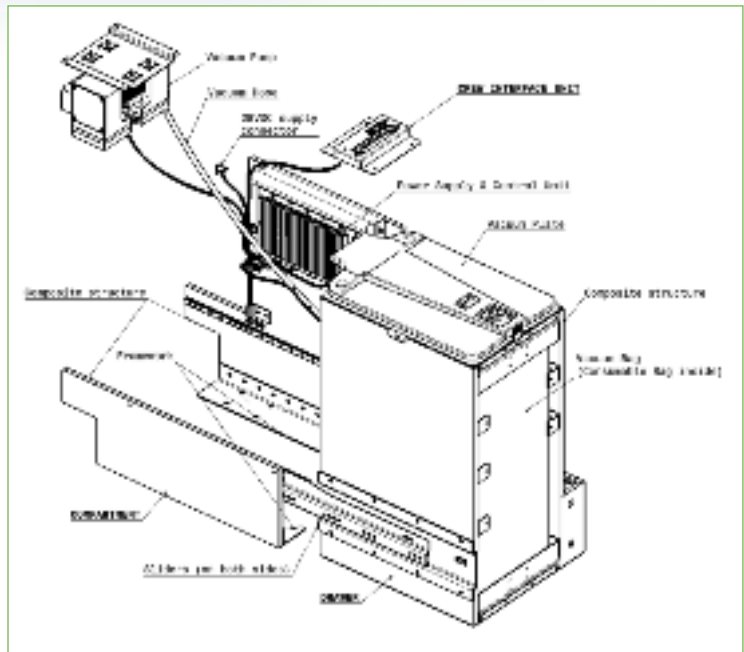
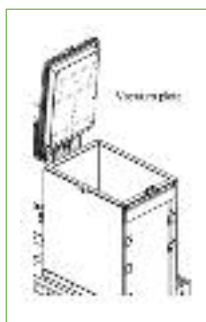

ONLINE MAINTENANCE

All components can be replaced online within 30 mns.

